



Interchangeable Virtual Instruments Foundation

IVI Foundation

Delivering Interchangeability and More

AUTOTESTCON 2008

Salt Lake City, Utah

September 2008

Agenda

- Goals, User and Member Benefits
- IVI Architecture
- Specifications
- Examples
- Continuing Efforts
- Questions and Open Discussion



IVI Foundation Overview

- Open consortium
 - End-users
 - System integrators
 - Instrument and software vendors
- Founded in August 1998, incorporated in March 2001
- 32 member companies
- Consolidated home for many SW standards
 - IVI Instrument Drivers
 - VXI*plug&play*
 - SCPI
 - LXI Synchronization
 - Synthetic Instruments



User Problem

“Test systems are difficult and expensive to develop and maintain”



IVI Solution

- IVI instrument drivers define a new level of...
quality,
completeness,
usability,
and functionality
that reduces the cost of test system
development and ownership



IVI Solution

- IVI drivers

- simplify upgrading or replacing components

- in complex test systems intended to be used over a long period of time



IVI Classes

■ Current Classes

- DMM
- Scope
- Switch
- Function Generator
- RF Signal Generator
- DC Power Supply
- Power Meter
- Spectrum Analyzer



User Benefits

- **Hardware Interchangeability** – Protect test software investment and reduce lifecycle costs with instrument interchangeability
- **Software Interoperability** – Leverage software between common programming environments, ease multi-vendor software integration and enhance maintainability
- **Reduced Test Development Effort** – Additional features such as instrument I/O simulation make building test systems easier.
- **Quality** – Improved performance and consistency



IVI Member Benefits

- Influence the development of instrument class standards
- Participate in and access future architectural standards
- Share ideas with developers, users, system integrators and vendors
- Access source code for shared components
- Participate in interoperability sessions
- Network with test and measurement industry leaders



IVI Specifications

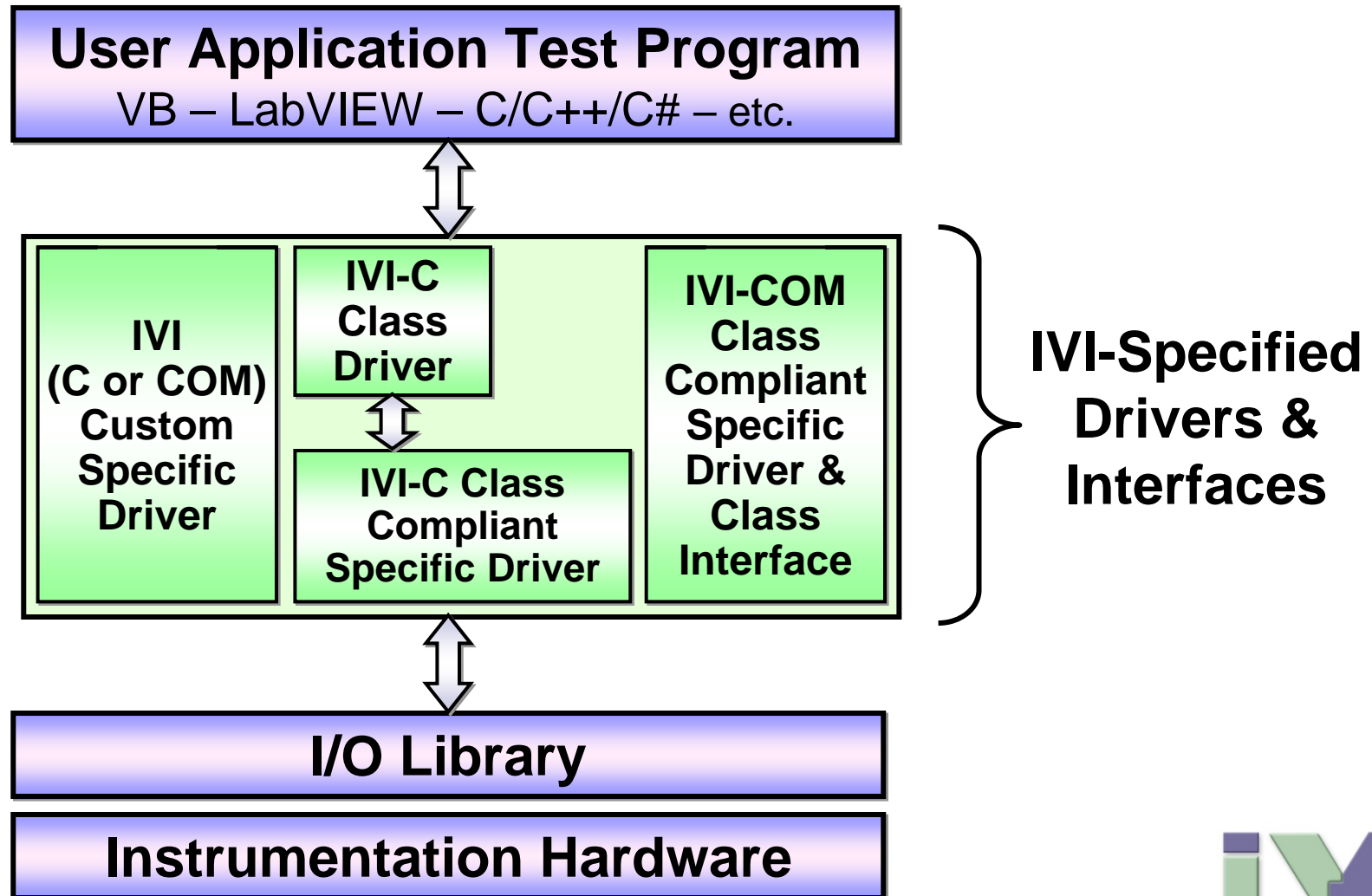

IVI Architecture

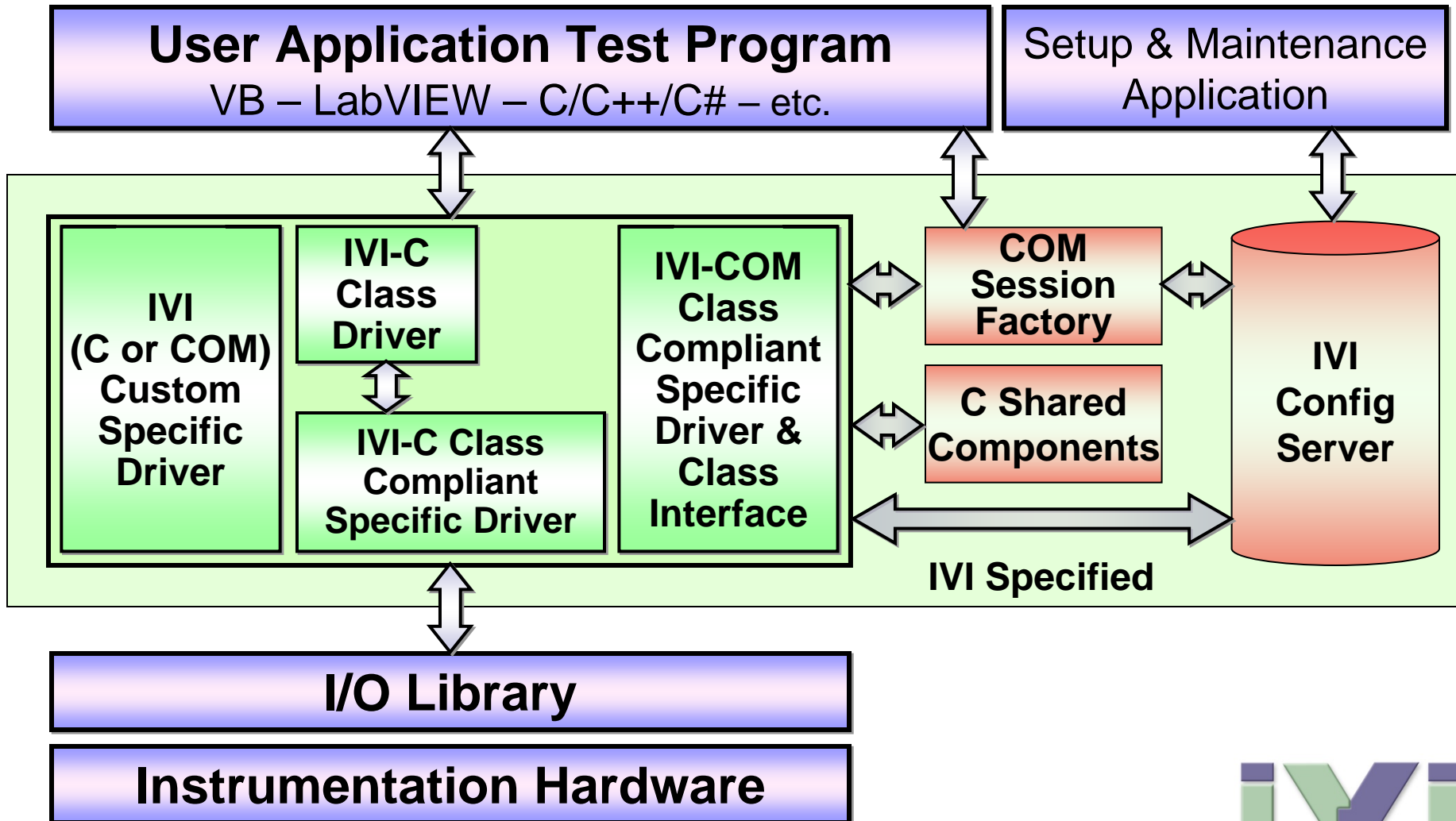

IVI Foundation Working Groups

- To achieve desired benefits, working groups in two focus areas
 - Architecture and technology specifications
 - Instrument class specifications



IVI Foundation Working Groups

Architecture & Technology Specifications

Spec #	Spec Name
IVI-3.1	Driver architecture specification
IVI-3.2	Inherent capabilities specification
IVI-3.3	Standard cross-class capabilities specification
IVI-3.4	API style guide
IVI-3.5	Configuration server specification
IVI-3.6	COM session factory specification
IVI-3.9	C shared components specification
IVI-3.10	Measurement and stimulus subsystems specification
IVI-3.12	Floating-point services specification
IVI-3.14	PrimaryInterop Assembly Specification
IVI-3.15	IviLxiSync Specification
IVI-5.0	Glossary



IVI Foundation Working Groups

Instrument Class Specifications

Spec #	Spec Name
IVI-4.1	Oscilloscope class specification
IVI-4.2	DMM class specification
IVI-4.3	Function generator/Arb class specification
IVI-4.4	DC power supply class specification
IVI-4.6	Switch class specification
IVI-4.7	Power meter class specification
IVI-4.8	Spectrum analyzer class specification
IVI-4.10	RF signal generator class specification



IVI Shared Components

- C Shared Components
- Floating Point Services
- IVI-COM Session Factory
- Configuration Server
- COM Type Libraries
- .NET PIAs



IVI Benefits

- Instrument simulation
- Improved system performance
- Ease of use & higher quality
- AND interchangeability



Benefits

Instrument Simulation

- Develop and test code without instrument
 - Configuration steps accepted by driver
 - Driver returns driver defined results
- Reduces HW investment during development

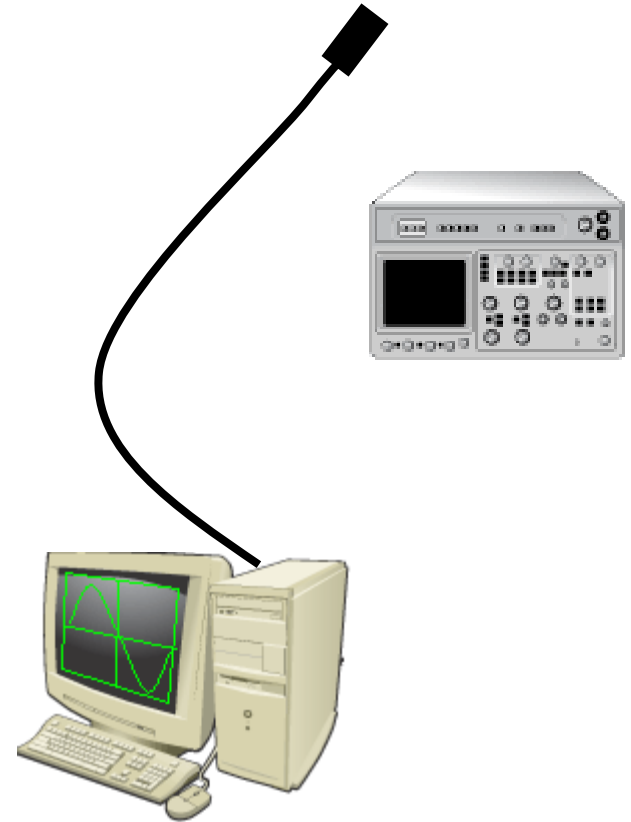

Benefits

Improved System Performance

- Thread-safe design enables multi-threaded execution
- API design includes properties for fast access
- State caching minimizes redundant I/O transactions

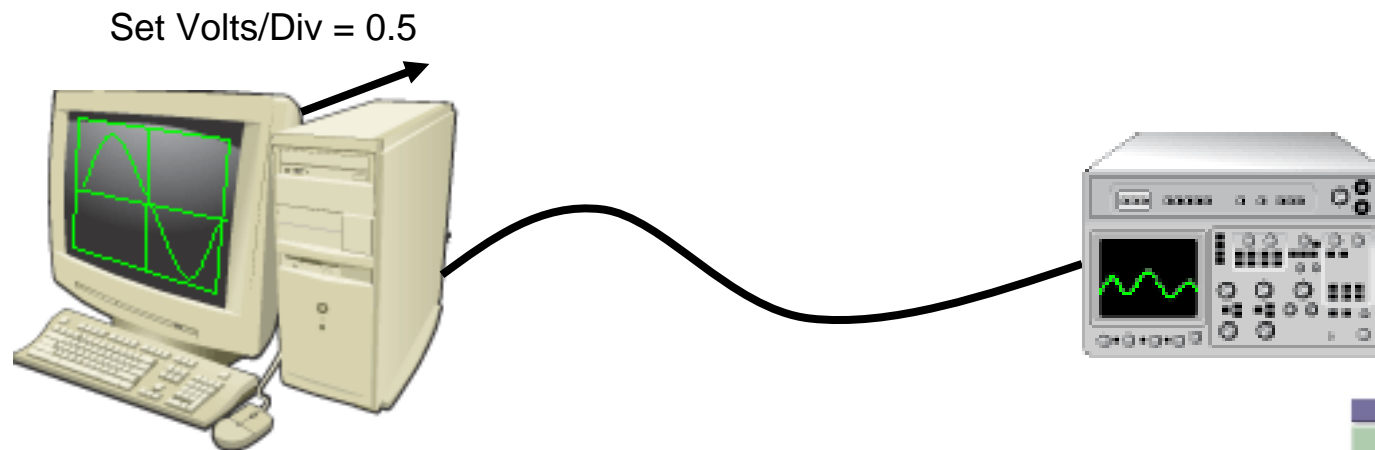

Benefits

Ease of Use & Higher Quality

- Driver quality and consistency
 - Instrument driver APIs
 - Installation and un-installation requirements
 - Standard system configuration components
- Shared components common code
- Ease of use
 - Easy to learn driver paradigm
 - Knowledge transfers to other drivers



IVI Features – Interchangeability

- Swap hardware between:
 - Instrument manufacturer (e.g., NI™ and Agilent)
 - Communication bus (e.g., GPIB and PXI™)

Test Program

(LabVIEW™, MeasurementStudio™, etc.)

DMM Class Driver

Fluke 45 or NI 4060



IVI Features – Interchangeability

- Protect software investment when hardware needs to be replaced
- Prevent downtime when repairing equipment
- Share software between users of different hardware

Test Program

(LabVIEW™, MeasurementStudio™, etc.)

DMM Class Driver

Fluke 45 or NI 4060



IVI Configuration

Associate Logical Names with Drivers and Hardware

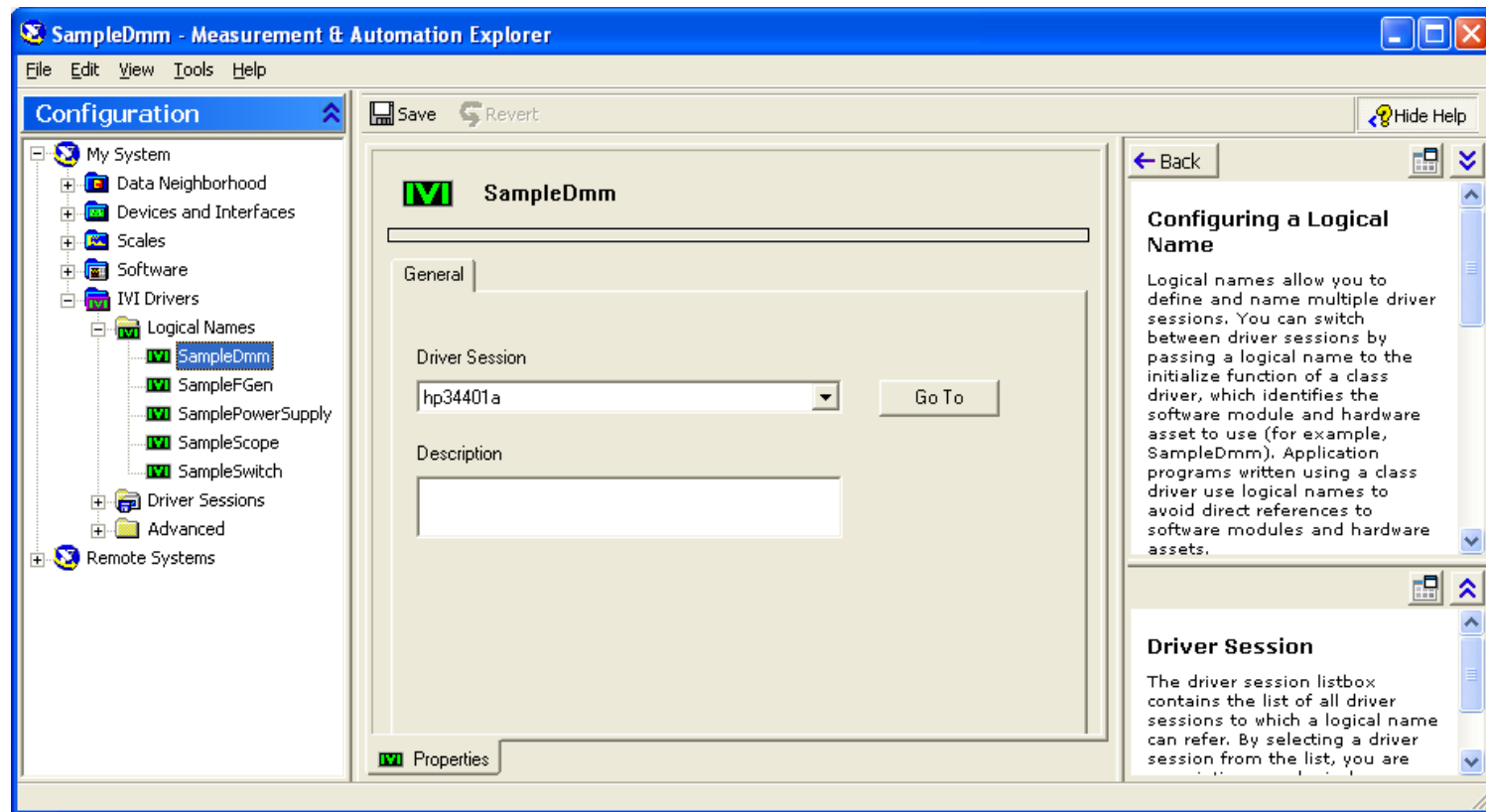

IVI Getting Started Guide

- Practical examples with step-by-step instructions
- Demonstrates ease of use in major ADEs
 - Developed by experts in these environments



Using IVI Drivers in C

```
#include <stdio.h>
#include "hp34401a.h"
main ()
{
    ViSession hp34401a;
    ViStatus  error = VI_SUCCESS;
    ViReal64  reading;
    ViChar    msgStr[256];
    checkErr( hp34401a_InitWithOptions ("ASRL1::INSTR", VI_TRUE, VI_TRUE,
                                        "Simulate=1,RangeCheck=1,QueryInstrStatus=1,C",
                                        &hp34401a));
    checkErr( hp34401a_ConfigureMeasurement (hp34401a, HP34401A_VAL_DC_VOLTS, HP34401A_VAL_DC_VOLTS));
    checkErr( hp34401a_Read (hp34401a, 5000, &reading));
    Fmt(msgStr, "%f", reading);
    MessagePopup("title", msgStr);
Error:
    if (error != VI_SUCCESS)
        {ViChar    errStr[2048];
         hp34401a_GetError (hp34401a, &error, 2048, errStr);
        }
    if (hp34401a)
        hp34401a_close (hp34401a);
}
```



Using IVI Drivers in LabVIEW

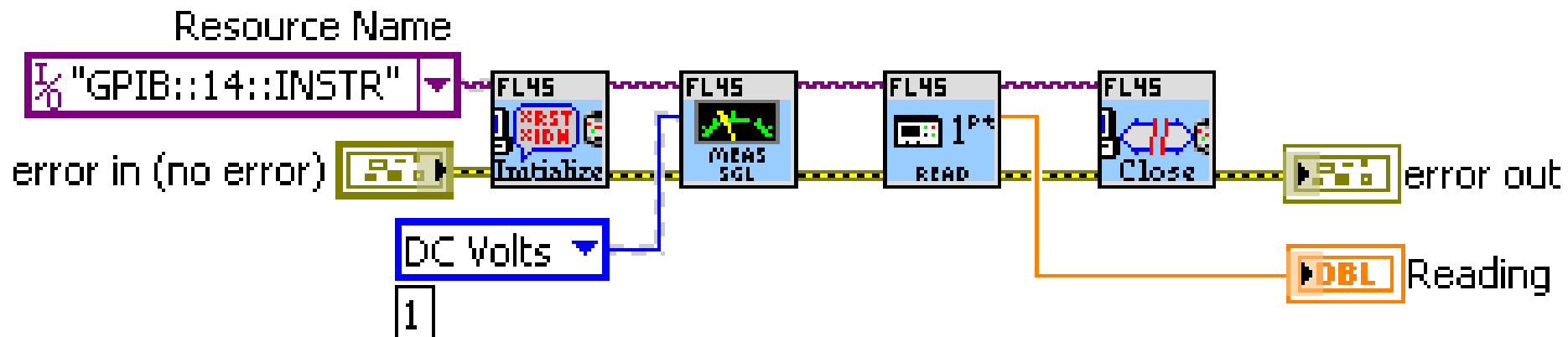

Using IVI Drivers in LabVIEW (cont.)

- Use property nodes to access low-level attributes

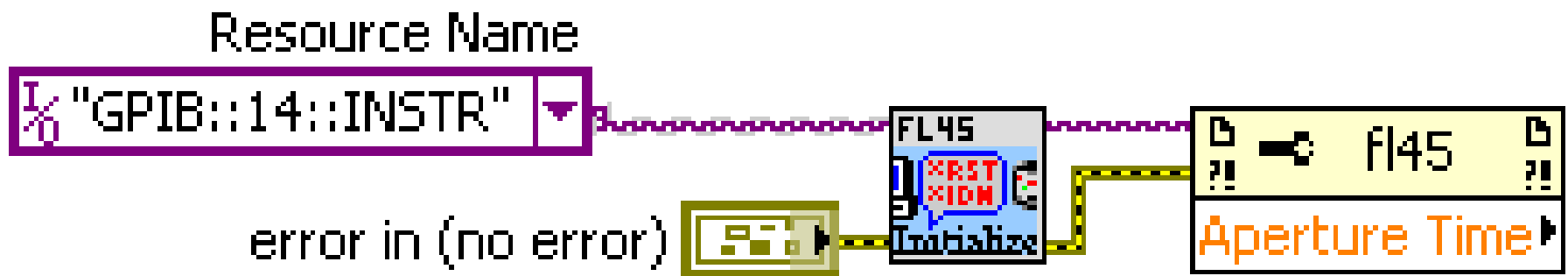
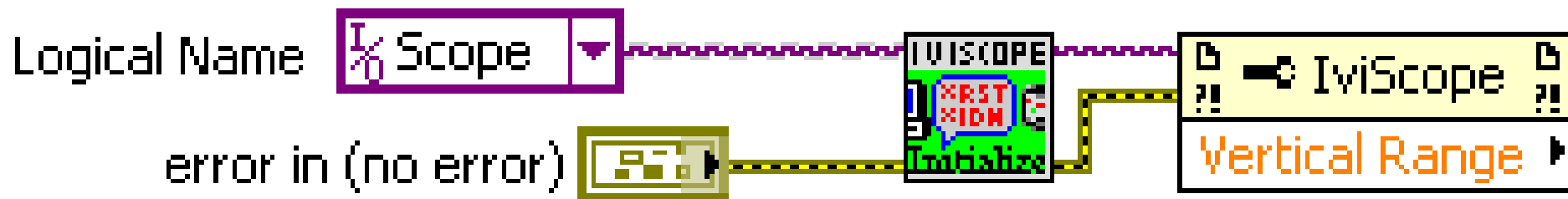

Class Driver vs. Specific Driver

	Class	Specific
General	One driver per class	One driver per instrument or family of instruments
Features	<ul style="list-style-type: none">• Class simulation• Interchangeability	<ul style="list-style-type: none">• Caching• Simulation• Multithreading
Example Functions	<ul style="list-style-type: none">• IviFgen_init• IviDmm_Read	<ul style="list-style-type: none">• Agilent 33120: hp33120a_init• NI 4072: niDmm_Read



Class Driver vs. Specific Driver

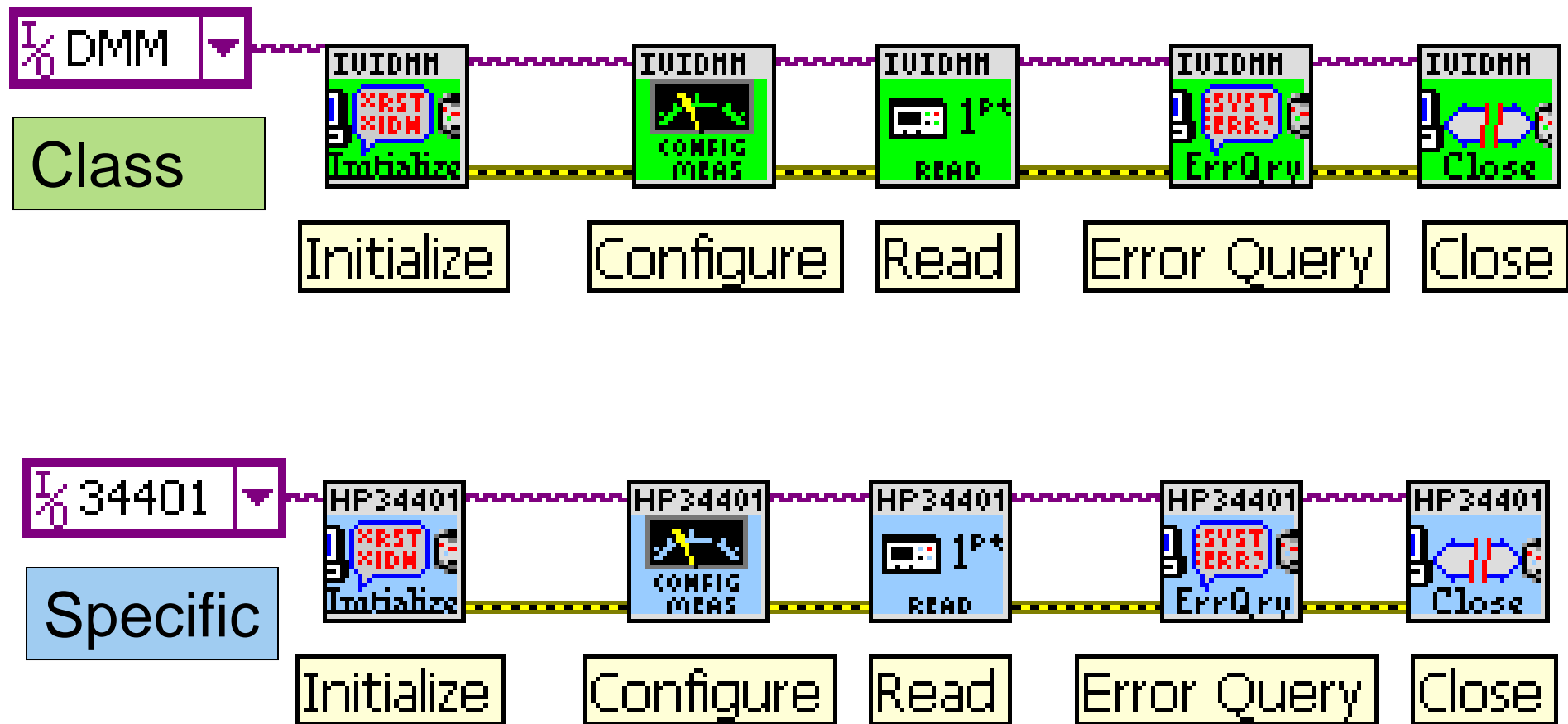

Class and Specific Drivers Together

- Primarily use Class functions, but use Specific functions when needed
- Reduces interchangeability of application

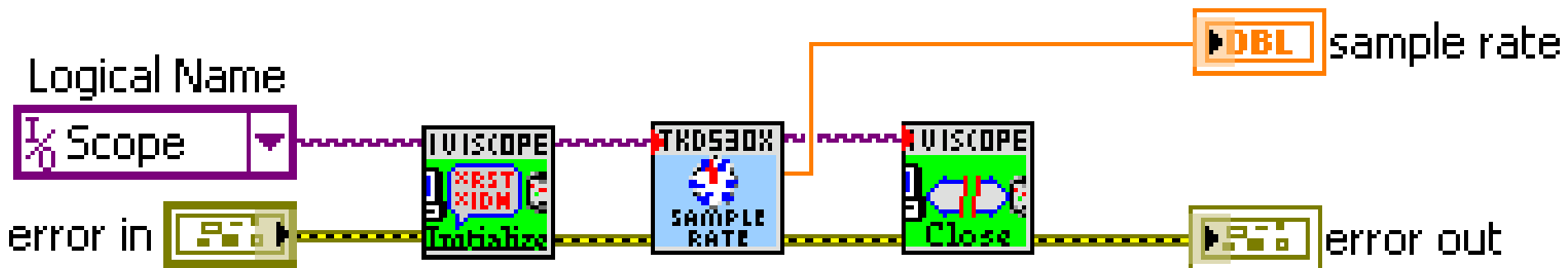

IVI-COM and IVI-C in LabVIEW

Agilent34410Lib.IAgilent34410

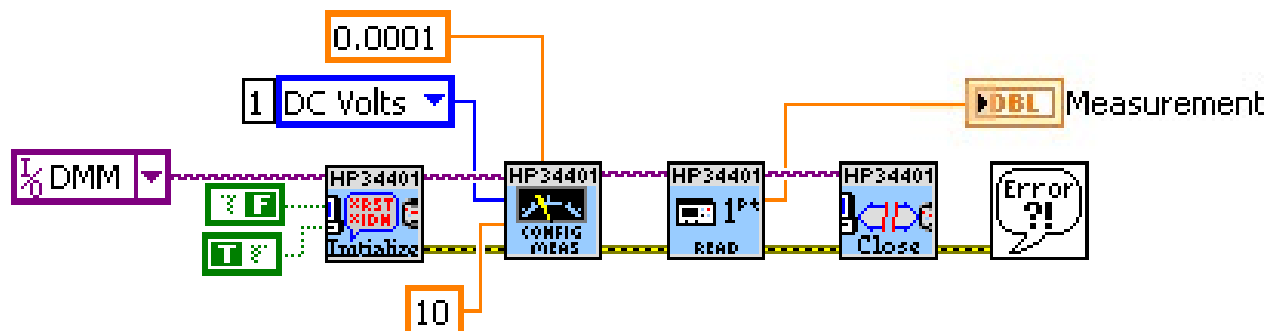
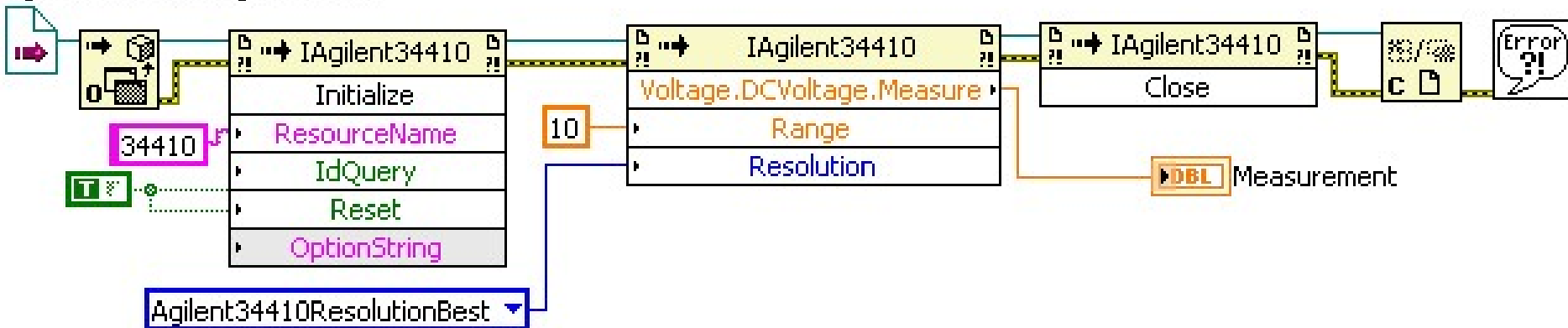

Specs Under Development

- Class specifications
 - Frequency Translation
 - Data Conversion
 - AC Power Supply
 - Counter Timer
- Architecture and technology specifications
 - .NET architecture for IVI
 - Windows Vista and 64-bit support



Additional Information

■ For more information or to join:

IVI Foundation Corporate Office
Bob Helsel, Director of Services
IVI Foundation
PO Box 1016
Niwot, CO 80544-1016

■ **Web:** www.ivifoundation.org

■ **Additional Resources:**

IVI Overview Tri-fold:

- http://www.ivifoundation.org/docs/IVI_TriFold_Brochure_Final.pdf

IVI Getting Started Guide:

- http://www.ivifoundation.org/downloads/IVI_GSG_v_1.0.pdf

